

# Towards Adaptive Autonomous Aerial Systems for Post-Disaster Communication

Julian Zobel

Multimedia Communications Lab (KOM)

Technische Universität Darmstadt

julian.zobel@kom.tu-darmstadt.de

**Abstract**—Digital wireless communication is used everywhere and has significant importance for our society. If required infrastructure is inhibited or destroyed, such as after natural disasters, delay-tolerant Mobile Ad Hoc Networks (DTN-MANETs) can offer relief by re-establishing communication without an existing infrastructure. However, message dissemination relies on node mobility, which may be low or non-existing especially in a post-disaster scenario. Utilizing Unmanned Aerial Vehicles (UAVs) as message collection and distribution platforms can compensate the effects of low mobility and support ad hoc communication. First simulation results suggest that communication bridges formed by UAVs between separated network islands significantly improve message delivery rate and propagation delay. Deploying controlled high-mobility UAVs to support low-performance networks could lead to a new era of applications taking advantage of supported ad hoc communication, such as in the fields of Smart Cities and the Internet of Things.

Digital wireless communication is key to a successful management of our personal and work time, but it is also a hard requirement for most of the economy, politics, or public safety organization. It is used everywhere and has significant importance for our society. Especially for safety organizations, reliable communication is a prerequisite to manage and distribute rescue personnel efficiently, and thus, for helping people in need and saving lives [1]. Due to the heterogeneity and large amount of communicating devices which have to be connected, the favored means of communication are wireless [2]. Nevertheless, natural disasters can inhibit or destroy necessary infrastructure like LTE towers for cellular services, which leads to a total loss of communication. This stands in severe contrast to the high demand of communication required by emergency services, civilians and others during and after a catastrophe [3], [4].

Ad hoc communication between devices like smartphones and the formation of DTN-MANETs are well-known approaches for resilient communication without infrastructure, and thus, can be used in post-disaster scenarios [3], [4]. However, message dissemination requires node movement and frequent encounters between devices. As shown in a large field test [4], the strong tendency of humans to form individual groups and to concentrate around points-of-interest in disaster scenarios heavily contradicts these requirements and leads to periodically intermittent network islands. This results in slow and only partial message delivery, which is not sufficient for most applications for disaster reliefs [4], [5].

My research focuses on the deployment of Unmanned

Aerial Systems (UAS) for communication support, utilizing autonomous UAVs as highly mobile and controllable message collection and distribution platforms. Especially in disaster scenarios UAVs are advantageous over ground-based approaches due to their airborne nature, which makes them independent of blocked or destroyed roads and enables access to otherwise impassable areas. Furthermore, wireless communication in general benefits from the strong line-of-sight characteristics of aerial and ground-to-air links, which empowers UAVs to cover larger areas at the same time in comparison to devices on the ground [5], [6], or as sketched out in Figure 1, allows them to act as aerial relays between intermittent islands.

Challenges can be grouped in three research fields.

- 1) *Monitoring* addresses issues such as the acquisition of meaningful and accurate information about the DTN-MANET on the ground. The intermittent network islands have to be found in the first place, especially if no a-priori knowledge about points-of-interests is available. Furthermore, this information must be kept up-to-date to allow adapting to changing network topologies or requirements. A prominent research question is, therefore, how to utilize UAVs to acquire monitoring information and how to keep it up-to-date, depending on resources (i.e., the amount of required UAVs) which have to be spent to gain the required knowledge.
- 2) *Communication Bridging* regards the application and execution of strategies to provide communication sup-

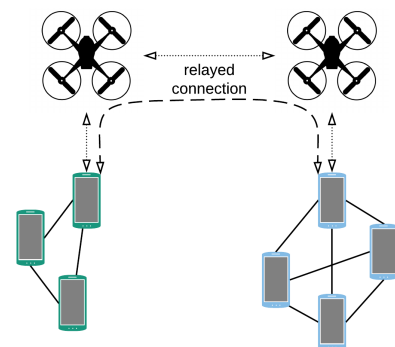

Fig. 1: Message relaying over UAVs enables inter-island communication among fully separated network islands.

port. This includes assessing the applicability of known strategies, but also the definition of new principles and strategies and their assessment under varying environments. They are defined by various influences, such as different network topologies, DTN-MANET protocols, or obtainable information, but also available UAVs, their speed, range, flight times, or battery sizes. The research question in my focus is how monitoring information can be utilized to create an adaptive autonomous support system, which can efficiently adjust executed strategies or completely exchange them with more appropriate strategies over the course of a scenario based on available knowledge.

- 3) *Control and Coordination* approaches the coordination of multiple UAVs by either a centralized entity or by using decentralized collaboration among the UAVs, and the information exchange between them. My research question in this field addresses the utilization of modern long-range low-power communication (e.g., LoRa) to establish wide-area control channels for the exchange of coordination and monitoring information in the UAS, but also how this technology can be used to interact, e.g., with available Smart City sensors to acquire additional sensor information. Due to limited bandwidth over long ranges, the question arises how to select the most valuable information for transmission, and which information can be discarded without significant losses in content or validity.

Due to poor scalability and reproducibility, and the requirement for expensive hardware prototypes of experimental evaluation, performing simulations is the preferred method for the assessment of complex systems. Thus, we developed an evaluation platform for Unmanned Aerial Systems (UAS) in combination with mobile ad hoc networks on top of an open-source simulation platform [7], which allows to address the previously mentioned research questions and challenges by simulations. A modular UAS design enables the implementation and exchange of multiple support strategies. Furthermore, a wide variety of simulation parameters like speed, battery size, or power consumption of UAVs, available communication devices and respective ranges, different DTN-MANET protocols, and movement models can already be used.

In its current state, however, simulations are restricted to multicopter UAVs only, but the complement of fixed-wing UAVs is currently in development. First results for a message ferrying strategy (cf. [8]) in an urban environment suggest that a single UAV establishes communication between fully separated network islands with reasonably small delay and high accuracy compared to pure DTN-MANET approaches (cf. Fig. 2). As a next step, the deployment in completely unknown environments should be enabled by detecting and assessing different monitoring strategies to acquire network information by UAV. This will give the foundation to allow for adaptivity of the applied strategies and eventually the whole UAS. It will further include the utilization of new

communication technologies, such as LoRa, to evaluate their usability for wide-area dissemination of monitoring information, transfer of high-priority messages like emergency calls, or as general communication channel for control and coordination of multiple UAVs. The evaluation of Unmanned Aerial Communication Support Systems in several different application scenarios like disaster relief, IoT [9], or animal monitoring [8] is a long-term contribution of my research. Eventually, real world field tests with multiple UAVs in the air are envisioned.

Summarizing, deploying UAVs as controllable and highly-mobile message collection and dissemination platforms has great potential for many scenarios, such as disaster relief, Smart Cities, and the Internet of Things. As shown in our preliminary study in a post-disaster scenarios, a small number of UAVs already has a significant impact on message dissemination and propagation delay. In the near future, more applications employing autonomous UAVs for communication support and message dissemination will arise. My research will ultimately answer questions of efficient and adaptive deployments of Unmanned Aerial Systems for ad hoc network communication support, to which the current results already contribute today.

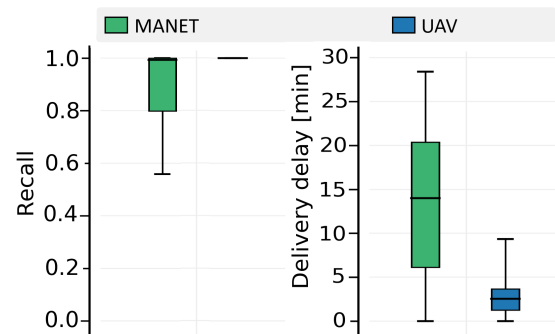

Fig. 2: Message recall and propagation delay for unsupported and supported MANETs.

## REFERENCES

- [1] M. Erdelj *et al.*, “Wireless sensor networks and multi-UAV systems for natural disaster management,” *Computer Networks*, 2017.
- [2] U. Raza *et al.*, “Low power wide area networks: An overview,” *IEEE Communications Surveys & Tutorials*, 2017.
- [3] P. Lieser *et al.*, “Architecture for responsive emergency communications networks,” in *Global Humanitarian Technology Conference (GHTC), 2017 IEEE, IEEE*, 2017.
- [4] F. Álvarez *et al.*, “Conducting a Large-scale Field Test of a Smartphone-based Communication Network for Emergency Response,” 2018.
- [5] L. Baumgärtner *et al.*, “Emergency communication in challenged environments via unmanned ground and aerial vehicles,” in *Global Humanitarian Technology Conference (GHTC), 2017 IEEE, IEEE*, 2017.
- [6] K. Namuduri *et al.*, *UAV Networks and Communications*. Cambridge University Press, 2017.
- [7] B. Richerzhagen *et al.*, “Simonstrator: Simulation and prototyping platform for distributed mobile applications,” 2015.
- [8] L. Pelusi *et al.*, “Opportunistic networking: data forwarding in disconnected mobile ad hoc networks,” *IEEE communications Magazine*, 2006.
- [9] M. Mozaffari *et al.*, “Mobile unmanned aerial vehicles (uavs) for energy-efficient internet of things communications,” *IEEE Transactions on Wireless Communications*, 2017.